

Drawn by: Udhay.N	Scale: 1:1	Date: 05/20/05	HARDWARE RESOURCES	
<p style="text-align: center;">TOLERANCES</p> <p style="text-align: center;">UNLESS OTHERWISE SPECIFIED TOLERANCES ARE IN METRIC</p> <p style="text-align: center;">OVER ALL LENGTH $\pm 0.1\text{MM}$ ANGLES $\pm 0^{\circ} 30'$</p>			PART NAME:	HR
			MATERIAL:	HR
			ITEM NO:	H5011
			PLATING:	HR

* - Critical Dimensions

Sheet 1/4

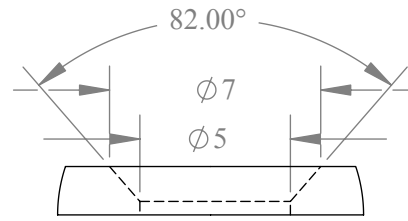
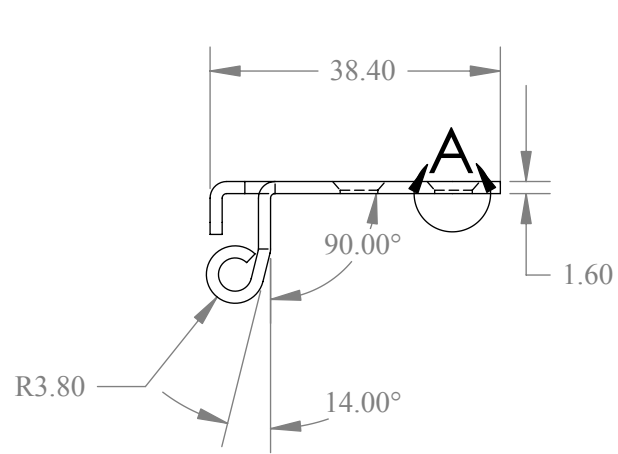

DETAIL A
SCALE 4 : 1

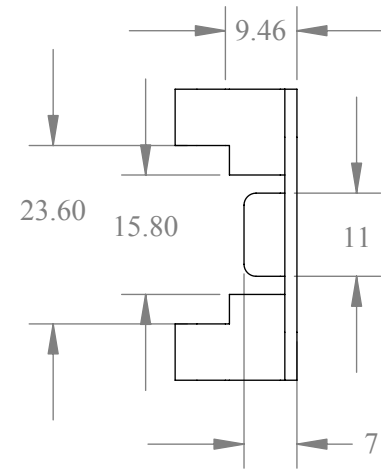
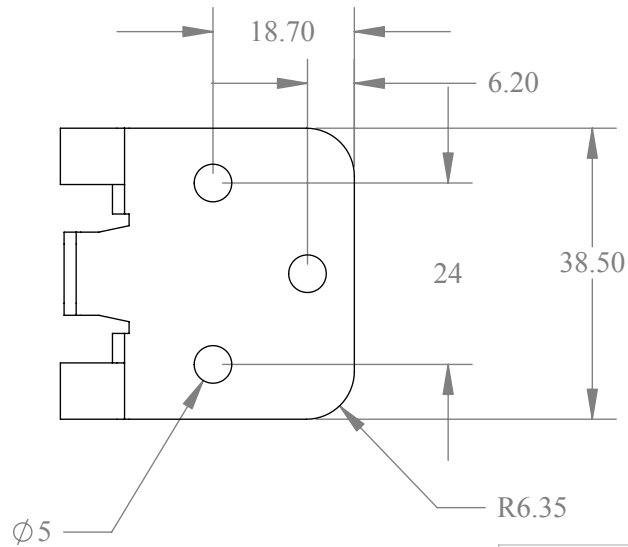
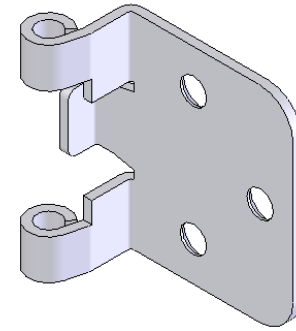

Drawn by: Udhay.N	Scale: 1:1	Date:
TOLERANCES UNLESS OTHERWISE SPECIFIED TOLERANCES ARE IN METRIC OVER ALL LENGTH ±0.1MM ANGLES ±0° 30'		

HARDWARE RESOURCES	
PART NAME:	HR
MATERIAL:	HR
ITEM NO:	H5011
PLATING:	HR

* - Critical Dimensions

Sheet 2/4

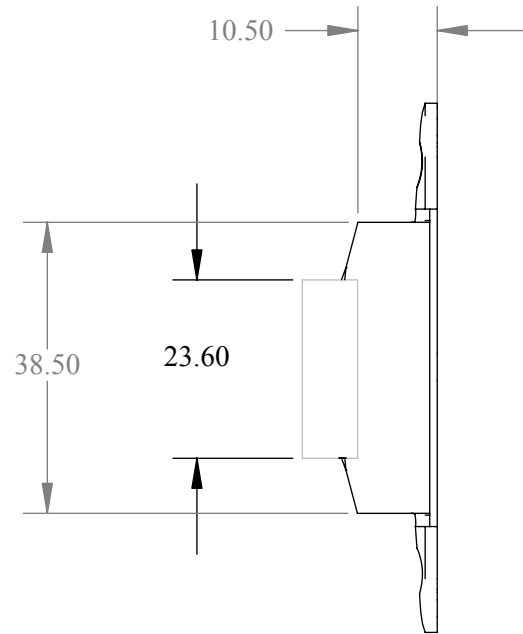
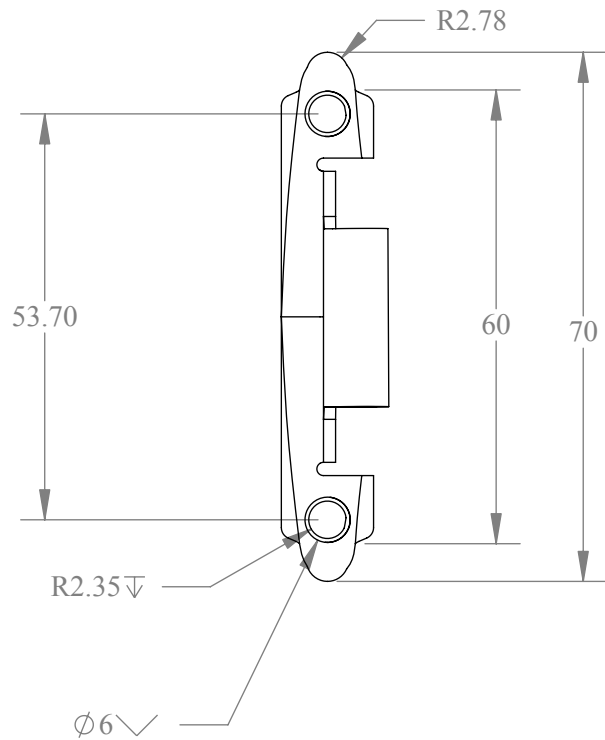
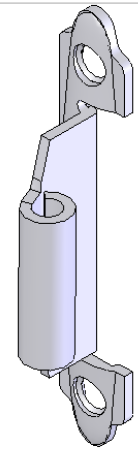
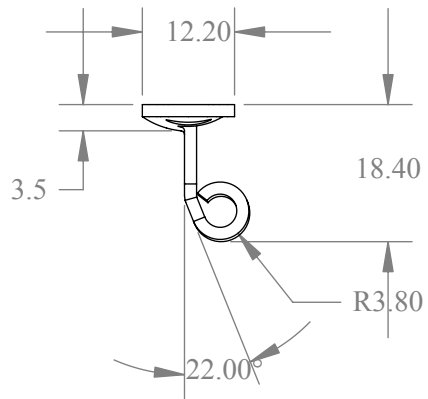

Drawn by: Udhay.N	Scale: 1:1	Date:	HARDWARE RESOURCES	
<p style="text-align: center;">TOLERANCES</p> <p style="text-align: center;">UNLESS OTHERWISE SPECIFIED TOLERANCES ARE IN METRIC</p> <p style="text-align: center;">OVER ALL LENGTH ±0.1MM ANGLES ±0° 30'</p>			PART NAME:	HR
			MATERIAL:	HR
			ITEM NO:	H5011
			PLATING:	HR

* - Critical Dimensions

Sheet 3/4

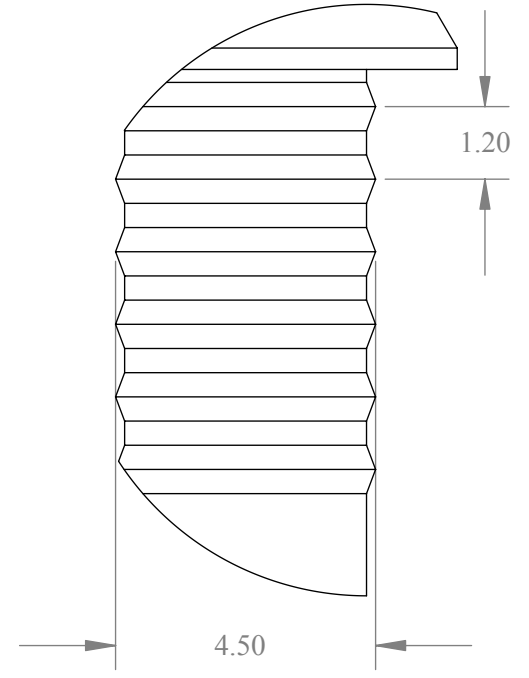
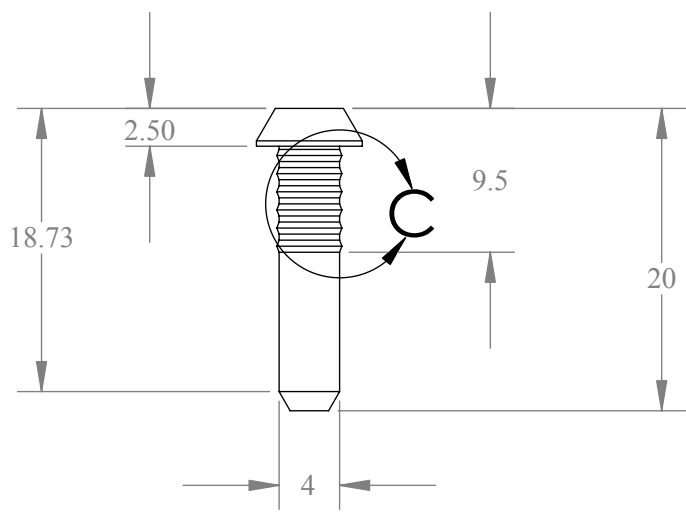
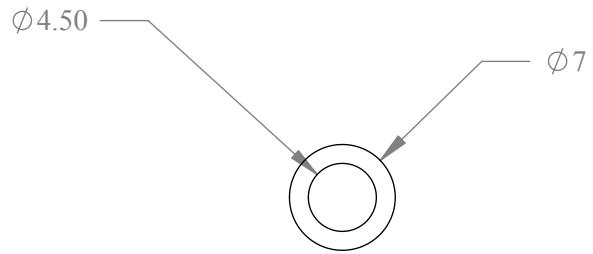

DETAIL C
SCALE 8 : 1

Drawn by: Udhay.N	Scale: 1:1	Date:	HARDWARE RESOURCES	
<p style="text-align: center;">TOLERANCES</p> <p style="text-align: center;">UNLESS OTHERWISE SPECIFIED TOLERANCES ARE IN METRIC</p> <p style="text-align: center;">OVER ALL LENGTH $\pm 0.1\text{MM}$ ANGLES $\pm 0^{\circ} 30'$</p>			PART NAME:	HR
			MATERIAL:	HR
			ITEM NO:	H5011
			PLATING:	HR

* - Critical Dimensions

Sheet 4/4